



REPUBLIC AVIATION CORPORATION  
FARMINGDALE, LONG ISLAND, NEW YORK  
• • • SERVICE DEPARTMENT • • •

May 1, 1947

No. 24

### SEABEE WIRING DIAGRAMS

These wiring diagrams apply to the Seabees, which have been delivered to date. Seabees Serial Numbers 5 through 425 inclusive were equipped with a Stewart Warner type instrument panel. This panel has electrical oil pressure, temperature, fuel pressure transmitters as well as electrical indicators. These indicators have to be supplied by the aircraft electrical supply. These airplanes also have a two magneto ignition system as shown on the diagram.

Seabees Serial Numbers 426 through 487 inclusive with the exception of 480 also have a two magneto ignition system but were equipped with an Autolite instrument panel which required no tee-in to aircraft electrical supply except for the fuel quantity indicator and transmitter.

Seabees Serial Numbers 480, 488 and up have a split ignition system as shown on the diagram. This system is explained in Seabee Service News No. 21. This group of Seabees are also equipped with the Autolite instrument panel.

In the future when any electrical changes are made new diagrams will be distributed showing these changes for the applicable group.

W. H. Ehmman  
Service Manager

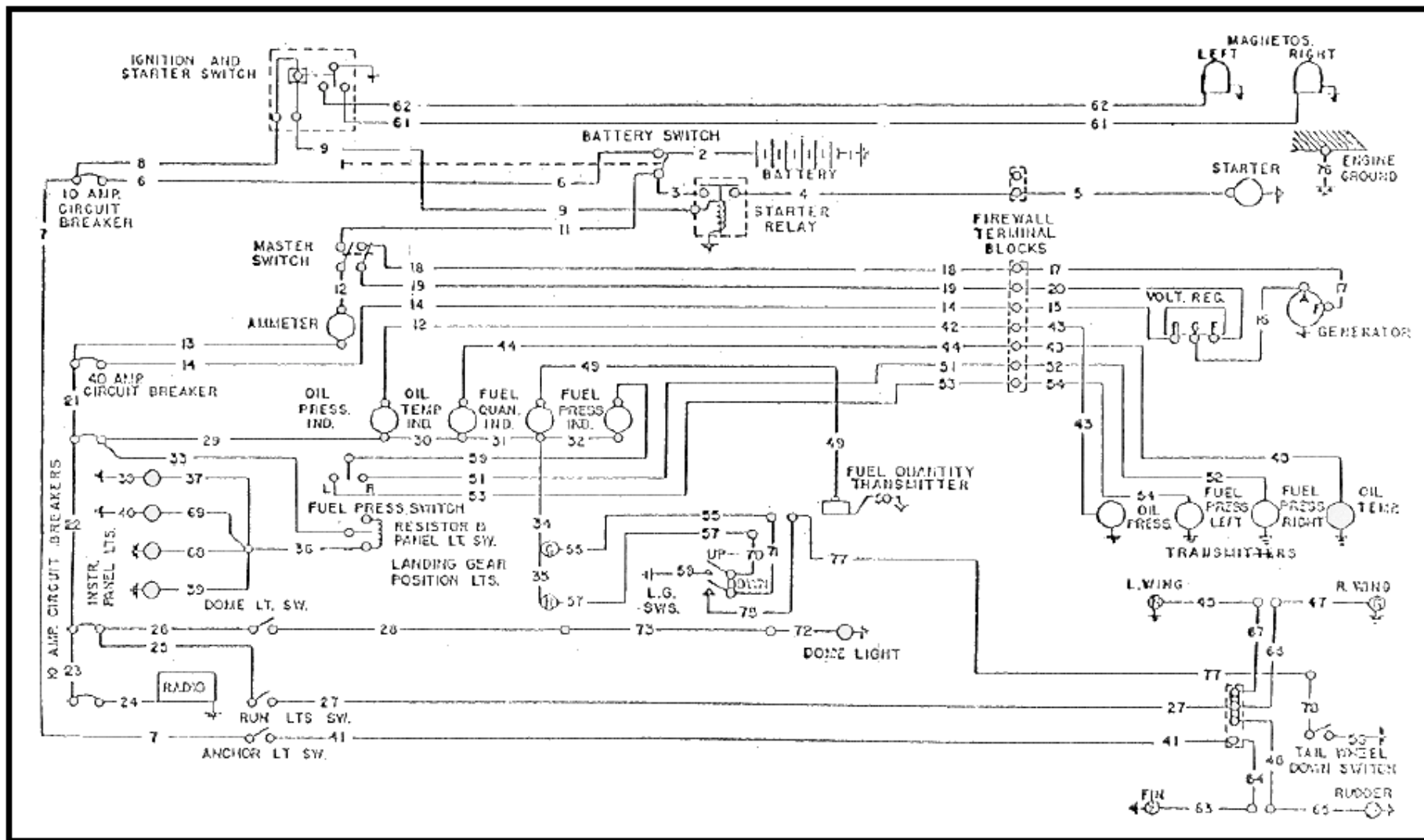

WIRING DIAGRAM

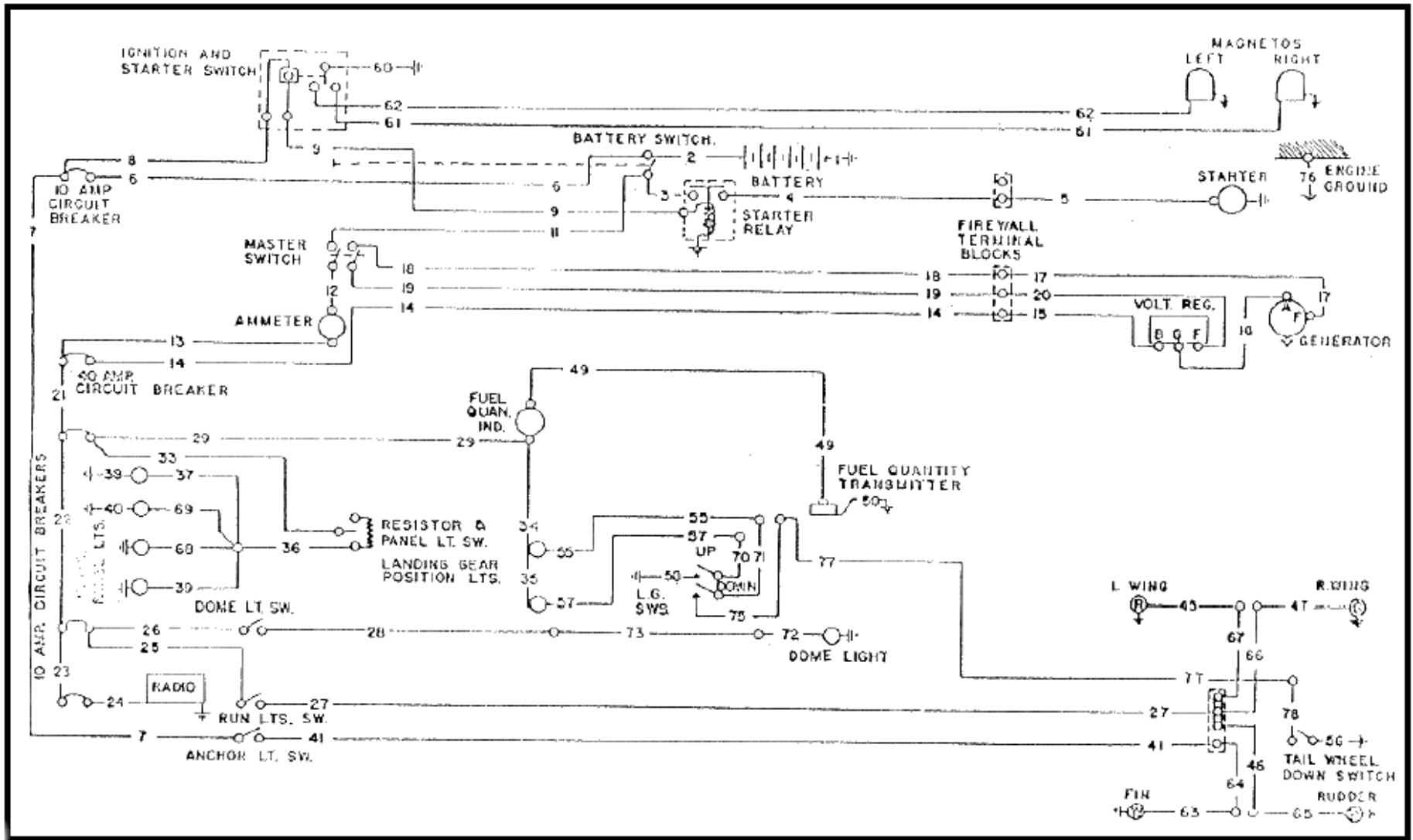

**WIRING DIAGRAM**

**Seabee Serial Nos. 426 through 487 inclusive; except 480**

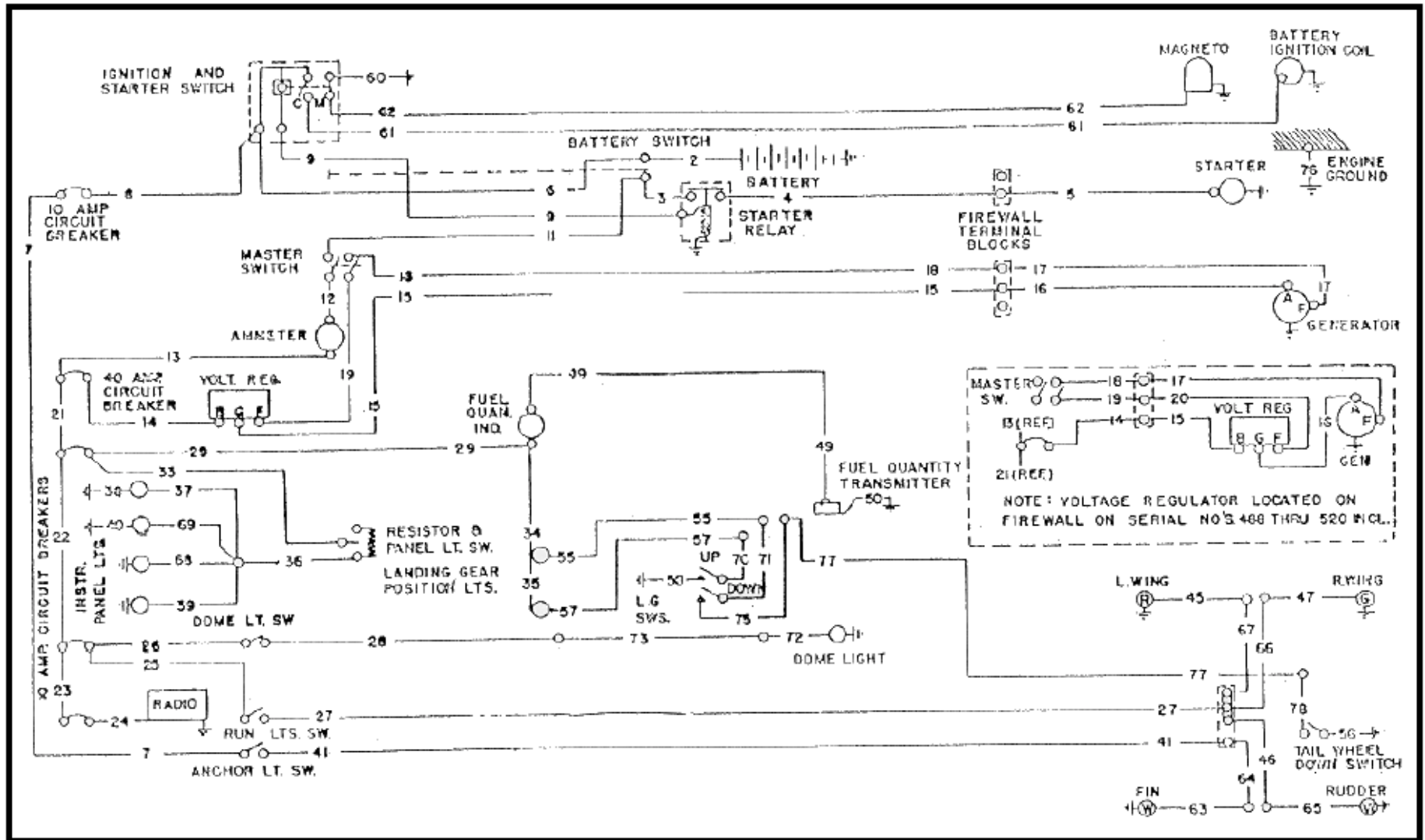

**WIRING DIAGRAM**  
**Seabee Serial Nos. 480, 488 and up.**