



REPUBLIC AVIATION CORPORATION
FARMINGDALE, LONG ISLAND, NEW YORK
SERVICE DEPARTMENT

MARCH 17, 1947

MANDATORY CHANGE

SERVICE BULLETIN NO. 12

INSPECTION AND ADDITION OF RELIEF HOLES AT
FLOAT STRUT SAFETY SLOTS

1. Add ½” and 1” diameter relief holes as shown on Figure 1 being certain not to lengthen existing slots. Either a drill or a file may be used. Also be certain that the edges of the holes are smooth and free from all nicks or new marks, burrs or file marks.
2. Reinstall strut and float and make suitable entry in log book.

W. H. Ehmann
Service Manager

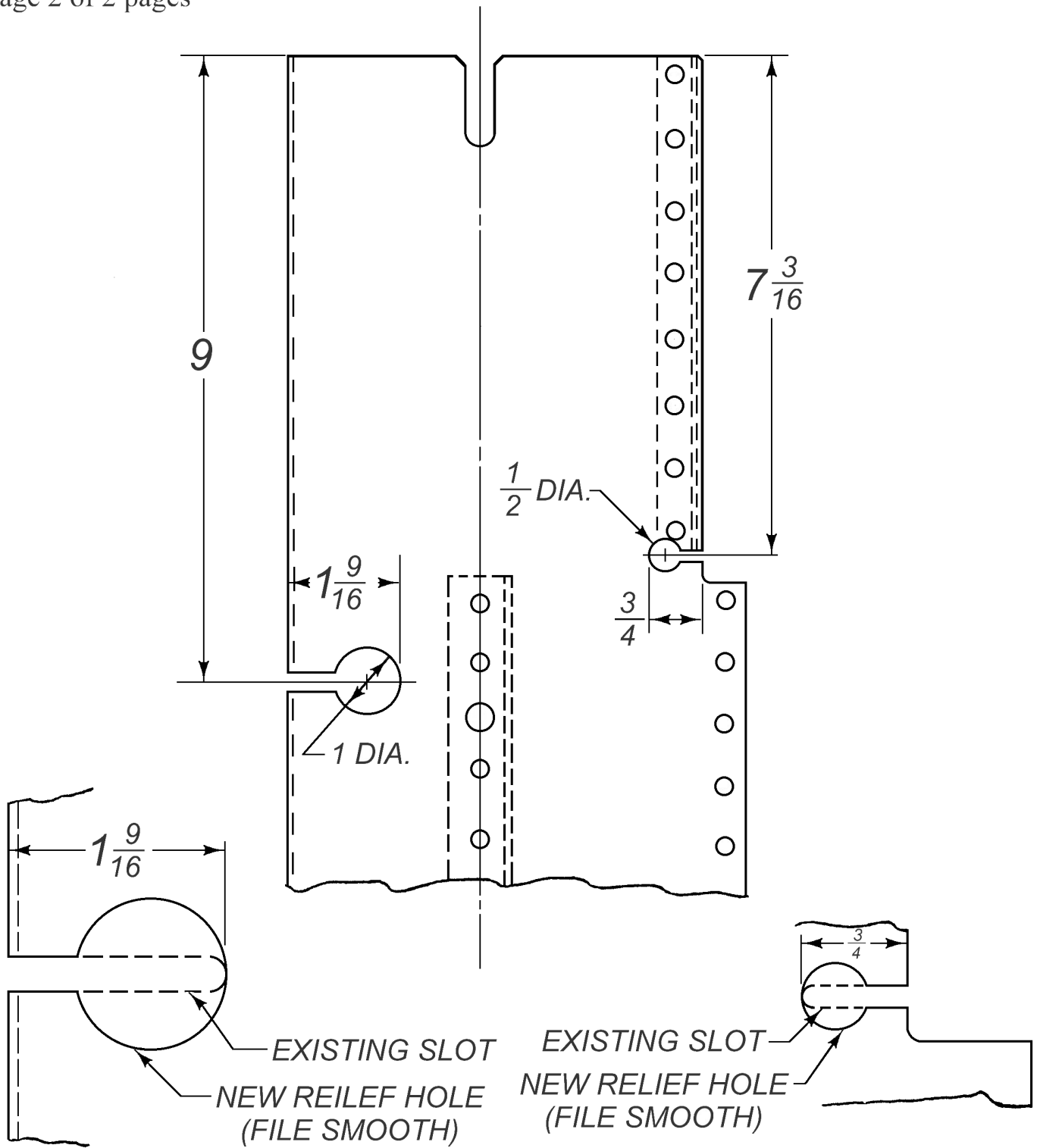

Figure 1