



US Department of Transportation
Federal Aviation Administration

MAJOR REPAIR AND ALTERATION (Airframe, Powerplant, Propeller, or Appliance)

Form Approved
OMB No. 2120-0020

For FAA Use Only

Office Identification

WR-27 MB

INSTRUCTIONS: Print or type all entries. See FAR 43.9, FAR 43 Appendix B, and AC 43.9-1 (or subsequent revision thereof) for instructions and disposition of this form. This report is required by law (49 U.S.C. 1421). Failure to report can result in a civil penalty not to exceed \$1,000 for each such violation (Section 901 Federal Aviation Act of 1958).

1. Aircraft	Make Republic	Model RC-3
	Serial No. 1000	Nationality and Registration Mark N5166B
2. Owner	Name (As shown on registration certificate) Davey Darrell L Davey Deborah A	
	Address (As shown on registration certificate) 6613 Santa Rosa Rd Camarillo Ca 93012-5672	

3. For FAA Use Only

oil Temp.

The data identified herein complies with the applicable airworthiness requirements and is approved for the above described aircraft, subject to conformity inspection by a person authorized in FAR 43, Section 43.7

8 Sep 99 *Michael B. Ben*
DATE SIGNATURE OAK-FSDO

4. Unit Identification

Unit	Make	Model	Serial No.	5. Type	
				Repair	Alteration
AIRFRAME	<i>~~~~~ (As described in Item 1 above) ~~~~~</i>				<input checked="" type="checkbox"/>
POWERPLANT					
PROPELLER					
APPLIANCE	Type				
	Manufacturer				

6. Conformity Statement

A. Agency's Name and Address	B. Kind of Agency	C. Certificate No.
Kenneth L. Thompson PO Box 411 Vineburg, Ca. 95487	<input checked="" type="checkbox"/> U.S. Certificated Mechanic	545767051
	<input type="checkbox"/> Foreign Certificated Mechanic	
	<input type="checkbox"/> Certificated Repair Station	
	<input type="checkbox"/> Manufacturer	

D. I certify that the repair and/or alteration made to the unit(s) identified in item 4 above and described on the reverse or attachments hereto have been made in accordance with the requirements of Part 43 of the U.S. Federal Aviation Regulations and that the information furnished herein is true and correct to the best of my knowledge.

Date 9-8-99	Signature of Authorized Individual <i>Ken Thompson</i>
-----------------------	---

7. Approval for Return To Service

Pursuant to the authority given persons specified below, the unit identified in item 4 was inspected in the manner prescribed by the Administrator of the Federal Aviation Administration and is **APPROVED** **REJECTED**

BY	FAA Fit. Standards Inspector	Manufacturer	<input checked="" type="checkbox"/> Inspection Authorization	Other (Specify)
	FAA Designee	Repair Station	Person Approved by Transport Canada Airworthiness Group	

Date of Approval or Rejection 9-8-99	Certificate or Designation No. 552273581	Signature of Authorized Individual <i>Douglas P. Smith</i>
--	--	---

NOTICE

Weight and balance or operating limitation changes shall be entered in the appropriate aircraft record. An alteration must be compatible with all previous alterations to assure continued conformity with the applicable airworthiness requirements.

8. Description of Work Accomplished

(If more space is required, attach additional sheets. Identify with aircraft nationality and registration mark and date work completed.)

Republic RC-3 N5166B Ser.# 1000

2. Description: Installed Mitchell oil temperature gauge part# D-12116067 in instrument panel and temperature sending unit part# 10-25180 in original sending unit location on engine and safety wired. Reference attached sheet. Temperature gauge marked for operating ranges as per STC#SA615NW. Circuit protection provided by a 1 amp fuse in panel mount fuse holder located underneath instrument panel. All work done in accordance with Mitchell installation instructions and AC 43.13 1A, Ch. 11, section 2, para. 424, 429, section 3, para. 442, 443, 445 thru 451, fig. 11.7a, section 7, para. 514 thru 520, ch. 16, section 1, para. 868, section 3, para. 894, AC 43.13 2A, ch.11, para, 211 thru 214.
3. Control, operation information: None
4. Servicing information: None
5. Maintenance instructions: Must be inspected annually in accordance with FAR 43 appendix D.
6. Trouble shooting information: None
7. Removal and replacement information: None
8. Diagrams: None
9. Special inspection requirements: None
10. Application of protective treatments: None
11. Data: Reference Mitchell installation instructions
12. List of special tools: None
13. For commuter category aircraft: N/A
14. Recommended overhaul periods: No additional overhaul time limitations
15. Airworthiness limitation section: No additional airworthiness limitations
16. Revision: A letter will be submitted to the local FSDO with a copy of the revised FAA form 337

Pg. 1 of 3

Additional Sheets Are Attached

REPUBLIC RC-3 N5166B SER#1000

Mitchell Oil Temperature Gauge Part# D-12116067

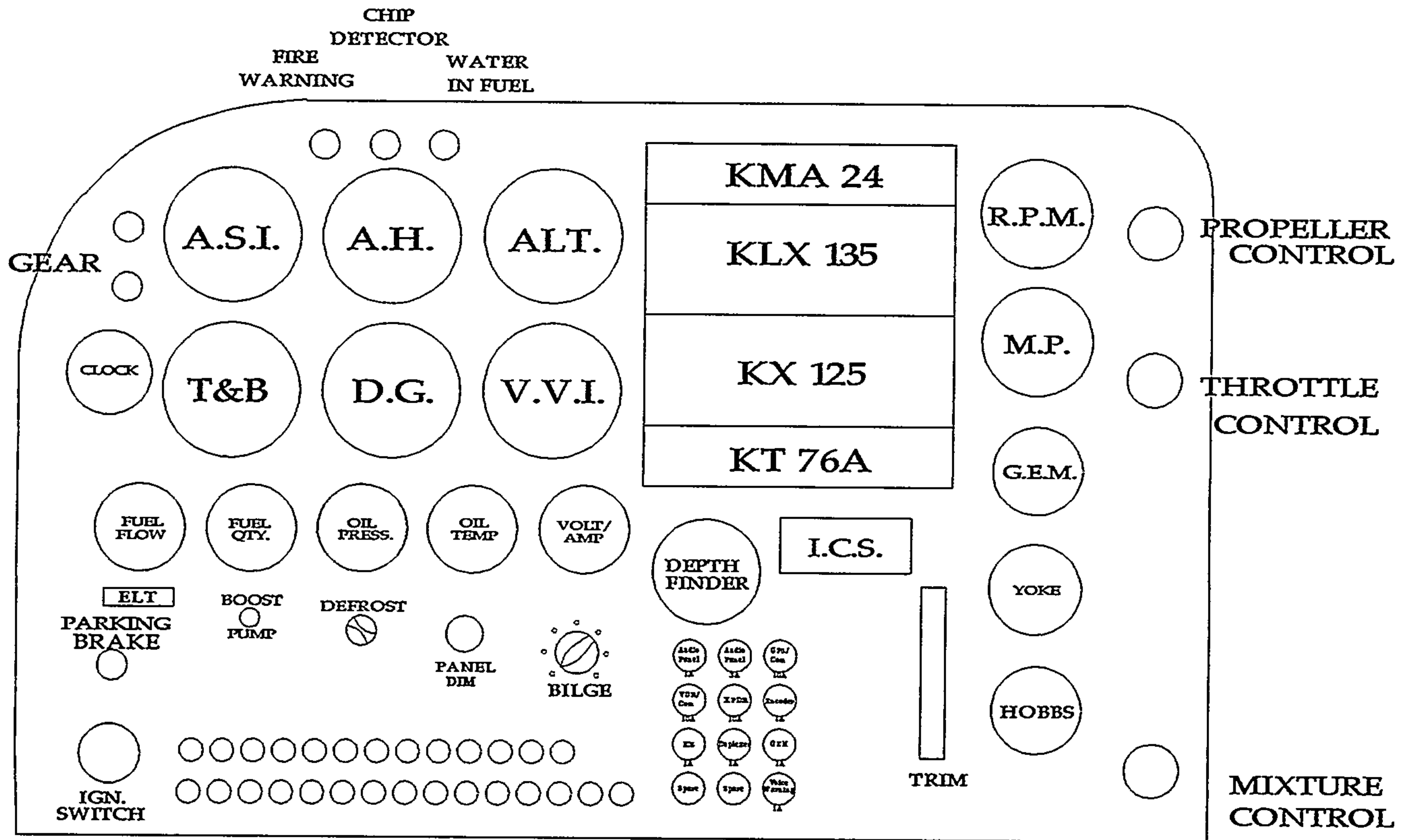

9-8-99

Republic RC-3 N5166B Ser# 1000

*Routing of MIL-C-27500 22 AWG shielded wire for Mitchell
Oil Temperature gauge Part# D12116067 to sending unit
Part# 10-25180.*

9-8-99

