



US Department of Transportation  
Federal Aviation Administration

## MAJOR REPAIR AND ALTERATION (Airframe, Powerplant, Propeller, or Appliance)

Form Approved  
OMB No. 2120-0020

**For FAA Use Only**

Office Identification

*WP-27 MB*

**INSTRUCTIONS:** Print or type all entries. See FAR 43.9, FAR 43 Appendix B, and AC 43.9-1 (or subsequent revision thereof) for instructions and disposition of this form. This report is required by law (49 U.S.C. 1421). Failure to report can result in a civil penalty not to exceed \$1,000 for each such violation (Section 901 Federal Aviation Act of 1958).

<b>1. Aircraft</b>	Make <b>Republic</b>	Model <b>RC-3</b>
	Serial No. <b>1000</b>	Nationality and Registration Mark <b>N5166B</b>
<b>2. Owner</b>	Name (As shown on registration certificate) <b>Davey Darrell L Davey Deborah A</b>	Address (As shown on registration certificate) <b>6613 Santa Rosa Rd Camarillo Ca 93012-5672</b>

**3. For FAA Use Only**

*Oil pressure gauge*

The data identified herein complies with the applicable airworthiness requirements and is approved for the above described aircraft, subject to conformity inspection by a person authorized in FAR 43, Section 43.7

*8 Sep 99*      *Miscel*      *Becker*  
DATE                      SIGNATURE                      OAK-FSDO

**4. Unit Identification**

Unit	Make	Model	Serial No.	5. Type	
				Repair	Alteration
AIRFRAME	<i>~~~~~ (As described in Item 1 above) ~~~~~</i>				<input checked="" type="checkbox"/>
POWERPLANT					
PROPELLER					
APPLIANCE	Type				
	Manufacturer				

**6. Conformity Statement**

<b>A. Agency's Name and Address</b>  <b>Kenneth L. Thompson</b> <b>PO Box 411</b> <b>Vineburg, Ca. 95487</b>	<b>B. Kind of Agency</b> <input checked="" type="checkbox"/> U.S. Certificated Mechanic <input type="checkbox"/> Foreign Certificated Mechanic <input type="checkbox"/> Certificated Repair Station <input type="checkbox"/> Manufacturer	<b>C. Certificate No.</b>  <b>545767051</b>
--	---	---

**D. I certify that the repair and/or alteration made to the unit(s) identified in item 4 above and described on the reverse or attachments hereto have been made in accordance with the requirements of Part 43 of the U.S. Federal Aviation Regulations and that the information furnished herein is true and correct to the best of my knowledge.**

Date <i>9-8-99</i>	Signature of Authorized Individual <i>Ken Thompson</i>
-----------------------	---

**7. Approval for Return To Service**

Pursuant to the authority given persons specified below, the unit identified in item 4 was inspected in the manner prescribed by the Administrator of the Federal Aviation Administration and is  **APPROVED**     **REJECTED**

<b>BY</b>	FAA Fit. Standards Inspector	Manufacturer	<input checked="" type="checkbox"/> Inspection Authorization	Other (Specify)
	FAA Designee	Repair Station	Person Approved by Transport Canada Airworthiness Group	
Date of Approval or Rejection <i>9-8-99</i>		Certificate or Designation No. <b>552273581</b>	Signature of Authorized Individual <i>Douglas P. Smith</i>	

## NOTICE

*Weight and balance or operating limitation changes shall be entered in the appropriate aircraft record. An alteration must be compatible with all previous alterations to assure continued conformity with the applicable airworthiness requirements.*

### 8. Description of Work Accomplished

*(If more space is required, attach additional sheets. Identify with aircraft nationality and registration mark and date work completed.)*

Republic RC-3      N5166B      Ser.# 1000

2. Description: Installed Mitchell oil pressure gauge part# D-12116067 in instrument panel and pressure sender part# 10-25045 in original location on engine. Oil pressure gauge marked for operating ranges in accordance with STC#SA615NW. Circuit protection provided by a 1 amp fuse in panel mount fuse holder under instrument panel. All work done in accordance with Mitchell installation instructions, AC 43.13 1A, Ch. 11, section 2, para.424, 429, section 3, para. 442, 443, 445 thru 451, fig. 11.7a, section 7, para. 514 thru 520, ch. 16, section 1, para. 868, section 3, para. 894, AC 43.13 2A, ch.11, para. 211 thru 214.

3. Control, operation information: N/A

4. Servicing information: None

5. Maintenance instructions: Must be inspected annually in accordance with FAR 43 appendix D.

6. Trouble shooting information: N/A

7. Removal and replacement information: None

8. Diagrams: None

9. Special inspection requirements: None

10. Application of protective treatments: None

11. Data: None

12. List of special tools: None

13. For commuter category aircraft: N/A

14. Recommended overhaul periods: No additional overhaul time limitations

15. Airworthiness limitation section: No additional airworthiness limitations

16. Revision: A letter will be submitted to the local FSDO with a copy of the revised FAA form 337

Pg. 1 of 2

Additional Sheets Are Attached

\*U.S.GPO:1994-568-012/00019

RC-3 N5166B SER#1000

# Mitchell Oil Pressure Gauge Location

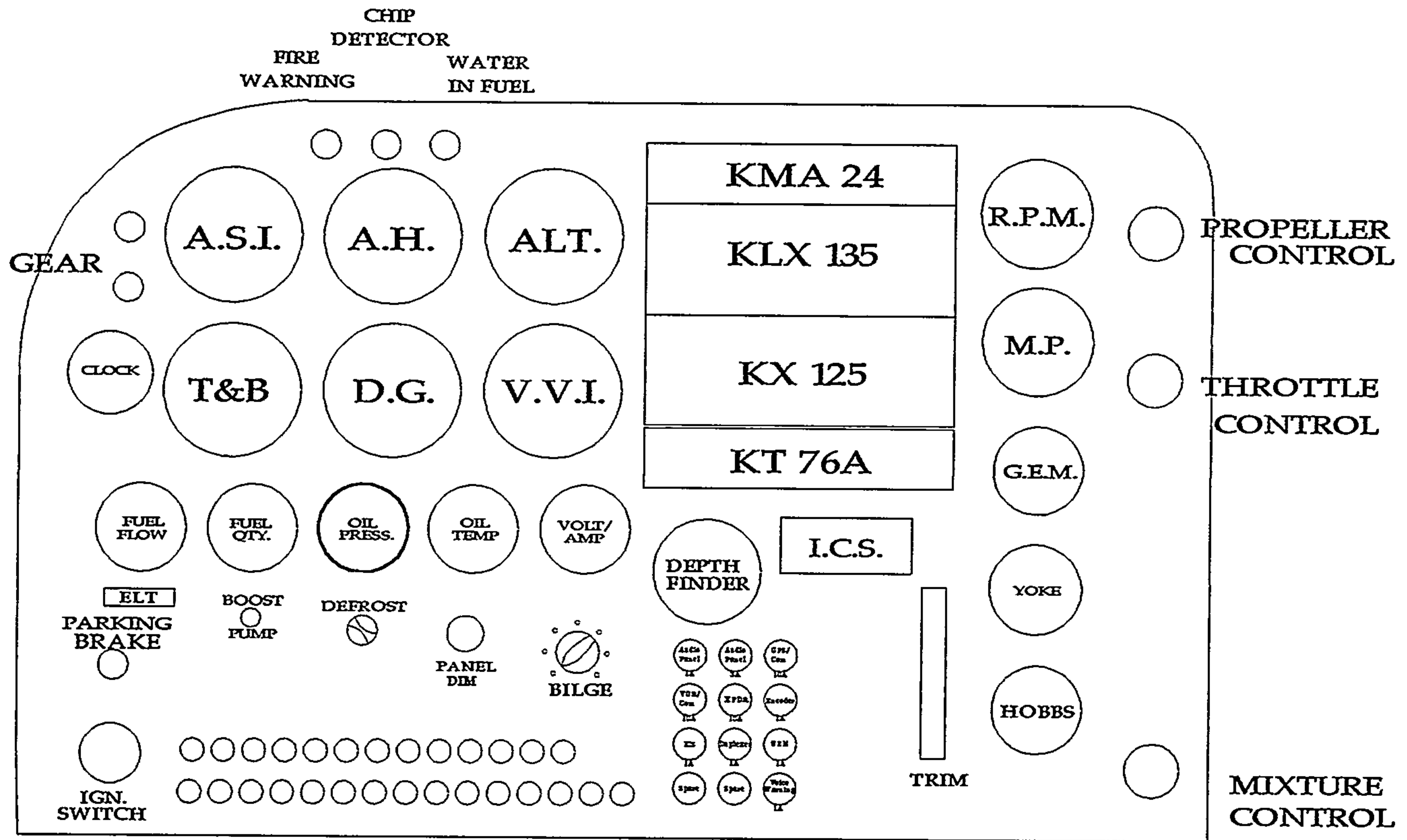

Pg. 2 of 2

9-8-99