



US Department of Transportation
Federal Aviation Administration

MAJOR REPAIR AND ALTERATION (Airframe, Powerplant, Propeller, or Appliance)

Form Approved
OMB No. 2120-0020

For FAA Use Only

Office Identification

WP-27 MS

INSTRUCTIONS: Print or type all entries. See FAR 43.9, FAR 43 Appendix B, and AC 43.9-1 (or subsequent revision thereof) for instructions and disposition of this form. This report is required by law (49 U.S.C. 1421). Failure to report can result in a civil penalty not to exceed \$1,000 for each such violation (Section 901 Federal Aviation Act of 1958).

1. Aircraft	Make Republic	Model RC-3
	Serial No. 1000	Nationality and Registration Mark N5166B
2. Owner	Name (As shown on registration certificate) Davey Darrell L Davey Deborah A	
	Address (As shown on registration certificate) 6613 Santa Rosa Rd Camarillo Ca 93012-5672	

3. For FAA Use Only

GEM

The data identified herein complies with the applicable airworthiness requirements and is approved for the above described aircraft, subject to conformity inspection by a person authorized in FAR 43, Section 43.7

20 Sep 99 *Michael J. Beck*
DATE SIGNATURE OAK-FSDO

4. Unit Identification

5. Type

Unit	Make	Model	Serial No.	Repair	Alteration
AIRFRAME	<i>~~~~~ (As described in Item 1 above) ~~~~~</i>				<input checked="" type="checkbox"/>
POWERPLANT					
PROPELLER					
APPLIANCE	Type				
	Manufacturer				

6. Conformity Statement

A. Agency's Name and Address Kenneth L. Thompson PO Box 411 Vineburg, Ca. 95487	B. Kind of Agency <input checked="" type="checkbox"/> U.S. Certificated Mechanic <input type="checkbox"/> Foreign Certificated Mechanic <input type="checkbox"/> Certificated Repair Station <input type="checkbox"/> Manufacturer	C. Certificate No. 545767051
--------------------------------------------------------------------------------------------------------------------------	-------------------------------------------------------------------------------------------------------------------------------------------------------------------------------------------------------------------------------------------------------	---------------------------------------------------

D. I certify that the repair and/or alteration made to the unit(s) identified in item 4 above and described on the reverse or attachments hereto have been made in accordance with the requirements of Part 43 of the U.S. Federal Aviation Regulations and that the information furnished herein is true and correct to the best of my knowledge.

Date 9-20-99	Signature of Authorized Individual <i>Ken Thompson</i>
------------------------	-----------------------------------------------------------

7. Approval for Return To Service

Pursuant to the authority given persons specified below, the unit identified in item 4 was inspected in the manner prescribed by the Administrator of the Federal Aviation Administration and is APPROVED REJECTED

BY	FAA Fit. Standards Inspector	Manufacturer	<input checked="" type="checkbox"/>	Inspection Authorization	Other (Specify)
	FAA Designee	Repair Station		Person Approved by Transport Canada Airworthiness Group	

Date of Approval or Rejection 9-20-99	Certificate or Designation No. 552273581	Signature of Authorized Individual <i>Douglas F. Smith</i>
-------------------------------------------------	----------------------------------------------------	---------------------------------------------------------------

NOTICE

Weight and balance or operating limitation changes shall be entered in the appropriate aircraft record. An alteration must be compatible with all previous alterations to assure continued conformity with the applicable airworthiness requirements.

8. Description of Work Accomplished

(If more space is required, attach additional sheets. Identify with aircraft nationality and registration mark and date work completed.)

Republic RC-3 N5166B Ser.# 1000

2. Description: Installed Insight Instrument Corp. Graphic Engine Monitor. GEM electrical circuit protected by a 1 amp fuse. All work done in accordance with Insight Installation Instructions Version 2.2, Dwg. 8258 and AC 43.13 1A, Ch. 11, section 2, para.424, 429, section 3, para. 442, 443, 445 thru 451, fig. 11.7a, section 7, para. 514 thru 520, and AC 43.13 2A, ch.11, para. 211 thru 214.
3. Control, operation information: Reference Insight Installation Instructions Version 2.2, Dwg. 8258
4. Servicing information: None
5. Maintenance instructions: Must be inspected annually in accordance with FAR 43 appendix D and FAR part 91.
6. Trouble shooting information: Insight Installation Instructions Version 2.2, Dwg. 8258
7. Removal and replacement information: None
8. Diagrams: None
9. Special inspection requirements: None
10. Application of protective treatments: None
11. Data: None
12. List of special tools: None
13. For commuter category aircraft: N/A
14. Recommended overhaul periods: No additional overhaul time limitations
15. Airworthiness limitation section: No additional airworthiness limitations
16. Revision: A letter will be submitted to the local FSDO with a copy of the revised FAA form 337

Pg. 1 of 3

Additional Sheets Are Attached

*U.S.GPO:1994-568-012/00019

GEM electrical installation diagram

Figures

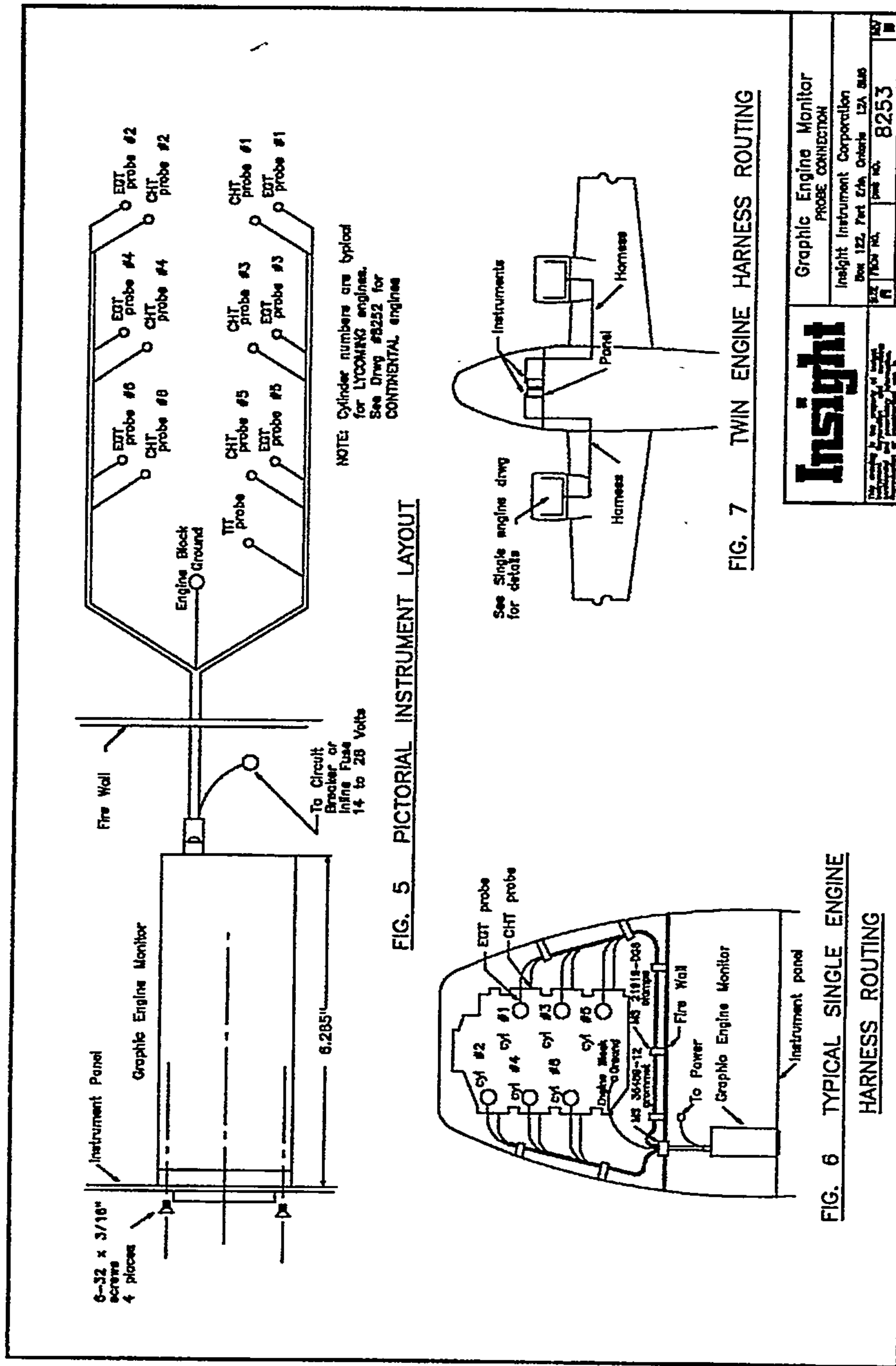

9-20-99

RC-3 N5166B SER#1000

Graphic Engine Monitor Location

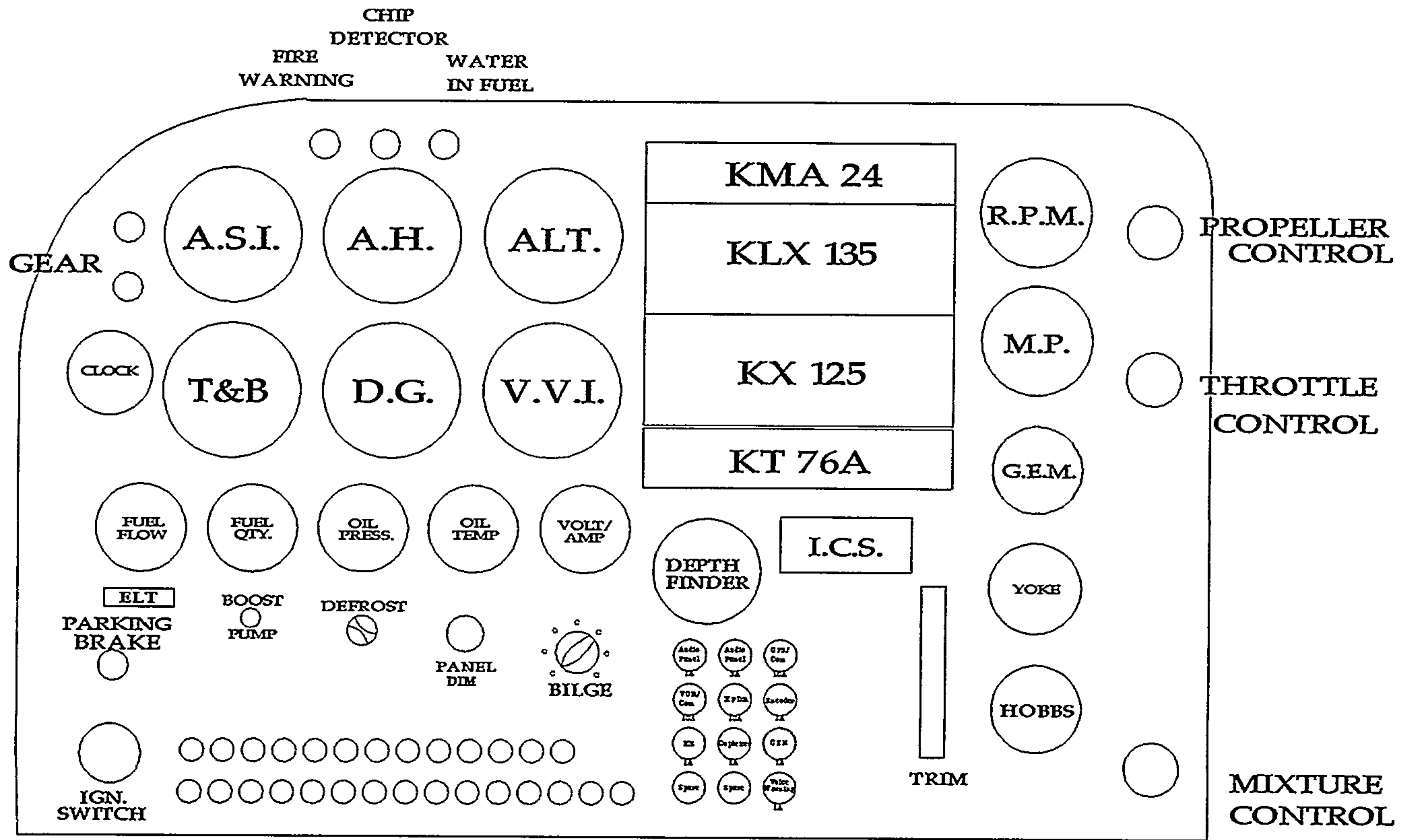

9-20-99